

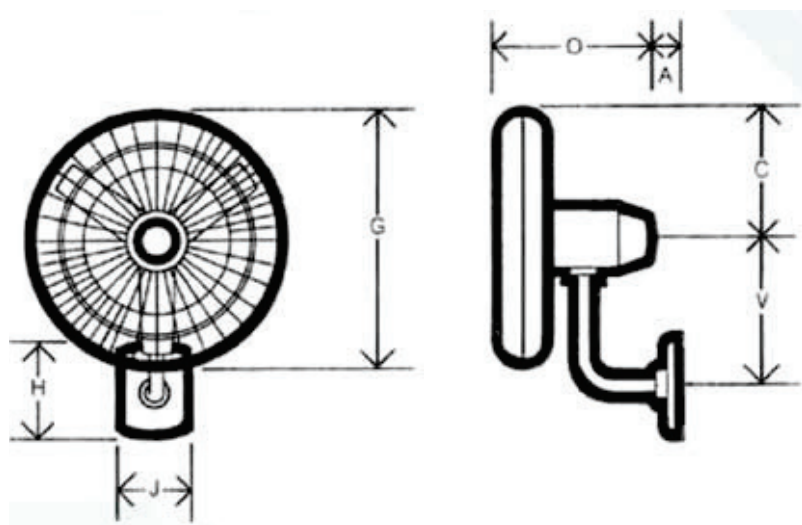

STAINLESS STEEL WALL FANS



- 1 & 3 phase versions
- IP 56 & IP 66 rating
- 2 speed motors (240V models only)
- Fixed head design - tilt & height adjustable
- GRP adjustable pitch blades
- Washdown duty / hoseproof rating

Wall Mounted (mm)	A (mm)	C (mm)	G (mm)	H (mm)	J (mm)	O (mm)	V (max) (mm)	Weight (kg)
460	80	265	525	220	205	440	320	21
630	80	345	690	220	205	440	320	23
810	80	435	870	220	205	440	320	25

Performance Data

Unit	Fan Diameter (mm)	Motor Speed (r/s)	Motor Power (kW)	*Noise dBA at 3m	Free Air Volume (L/s)
Wall Mounted	460	24	0.25	58	3000
Wall Mounted	630	24	0.25	60	6500
Wall Mounted	810	16	0.3	60	17000