

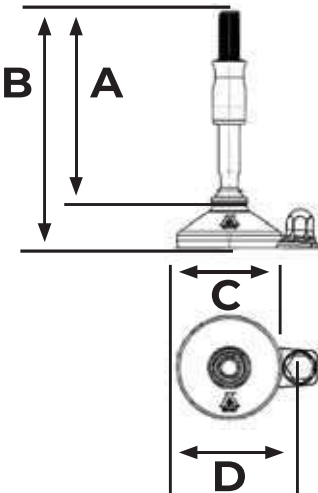

CERTIFIED HYGIENIC LEVELLING FEET



XH FIXING

3A, USDA, EHEDG	XH FIXING Certified Hygienic Levelling Foot. FDA Approved, Anti-Slip Rubber.				Max Static Load
	A	B	C	D	(N)
M16	150	178	65	46.8	30,800
	* 150	183	80	53.2	
	150	183	105	70	
	150	184	125	80	

* In Stock

All sizes in mm

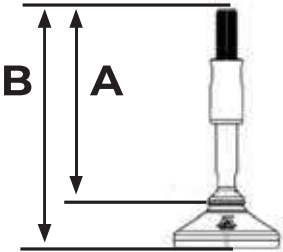

XH

3A, USDA, EHEDG	XH Certified Hygienic Levelling Foot. FDA Approved, Anti-Slip Rubber.			Max Static Load
	A	B	C	(N)
M16	150	178	65	30,800
	150	183	80	
	150	183	105	
	150	184	125	

All sizes in mm

More thread and length sizes available upon request

Also available



Type XHG + XHU - All movable parts are 100% hygienically sealed even if the load on the foot is removed. All sealings are blue and therefore detectable by scanning systems.

Minimum cleaning effort is obtained by the design of the self draining surfaces. Additionally, the foot is hygienically sealed to the floor by vulcanised FDA approved, anti-vibration, anti-slip runner, which blocks out bacteria underneath the footplate.

Type XHFVG + XHFVJ - The XHFVG and XHFVJ offer supreme height adjustability up to +/- 100mm as standard and has a sealed low-friction thread (lubricated for life).

Flexible mounting with optional flanges or thread adaptor, no risk of over adjusting the sleeve and thereby exposing the thread.